



## LS25-150 Series

Single Output General Purpose Power Supplies

- High MTBF up to 900 000 hours
- Superior operating temperature performance up to 70°C
- Very High efficiency up to 87%
- Very Low Cost
- Compact
- Withstands 300VAC surges (5s)
- Three Year Warranty

### Key Market Segments & Applications

Test & Measurement  
 Automated Service  
 Factory Automation  
 General Purpose  
 LED Lighting & Display

### LS25-150 Features and Benefits

#### Features

- High MTBF
- High efficiency
- -25 to +70°C operating temperature
- Low derating above 50 °C (up to 70% load available at 70° C)
- Curve B EMC

#### Benefits

- Superior Reliability
- Easier system cooling
- Suitable for indoor & outdoor enclosures
- Improved system power optimisation
- Assists system compliance

#### Specifications

ITEMS		LS25	LS35	LS50	LS75	LS100	LS150	
AC Input Voltage (300VAC for 5s)	VAC	88 - 264VAC (See note (2) for LS100)					88-132/176-264VAC(1)	
Input Frequency	Hz	47 - 63Hz						
DC Input Voltage	VDC	125 - 373VDC				248 - 273VDC		
Inrush Current (230VAC, cold start)	A	30	40	40	40	60	40	
Power Factor	-	Meets EN61000-3-2, -3						
Input Current (115/230VAC)	A	0.7 / 0.4	0.8 / 0.55	1.3 / 0.8	1.6 / 1.0	2.2 / 1.2	3.5 / 2	
Temperature Coefficient	-	<0.02%/°C (0 - 50°C)						
Overcurrent Protection	-	> 110%						
Overvoltage Protection	V	3.3V: 3.8-4.45V, 5V: 5.75-6.75V, 12V: 13.8-16.2V, 15V: 17.25-20.25V, 24V: 27.6-32.4V, 36V: 41.4-48.6V, 48V: 55.2-64.8V						
Hold Up Time (115 / 230V input)	ms	14 / 80	12 / 80	14 / 60	14 / 60	25 / 150	20 / 28	
Leakage Current (230VAC 60Hz)	mA	TBA		<1mA		<1mA		
Remote Sense	-	No						
LED Indicator	-	Green LED = On						
Operating Temperature	-	-25 to +70°C. Derate linearly to 50% load from +50 to +70°C (2)						
Storage Temperature	°C	-40 to +85°C						
Operating Humidity	-	20 - 90% RH (non condensing)						
Storage Humidity	-	10 - 95% RH (non condensing)						
Cooling	-	Convection						
Withstand Voltage	-	Input to Ground 1.5kVAC, Input to Output 3kVAC, Output to Ground 500VAC for 1 min.						
Isolation Resistance	-	>100MΩ at 25°C & 70%RH, Output to Ground 500VDC						
Vibration (non operating)	-	10 - 55Hz: 19.6m/s <sup>2</sup> constant sweep 1 min X, Y, Z for 1 hour						
Shock	-	< 196.1 m/s <sup>2</sup> (20G)						
Immunity	-	IEC61000-4-2, -3, -4, -5, -6, -8, -11						
Safety Agency Approvals	-	UL60950-1, EN60950-1, IEC60950-1, CE Mark						
Conducted & Radiated EMI	-	EN55011/EN55022-B, FCC-B						
MTBF (MIL-HDBK-217F)	hrs	906,997	706,464	712,890	648,786	545,375	505,393	
Weight (Typ)	g	170	270	350	410	600	700	
Size (LxWxH)	mm	79 x 51 x 28	99 x 82 x 36	99 x 97 x 36	130 x 97 x 38	160 x 97 x 38	198 x 99 x 38	
Warranty	yrs	3						

Model Selector							
Model	Voltage	Adjust Range (V)	Max Current (A)	Load Reg (mV)	Line Reg (mV)	Ripple Noise (mV)	Efficiency (typ) %
LS25-3.3	3.3V	3.0 - 3.3	6	66	16.5	80	72
LS25-5	5V	4.75 - 5.5	5	50	25	80	77
LS25-12	12V	10.8 - 13.2	2.1	60	60	120	79
LS25-15	15V	13.5 - 16.5	1.7	75	75	120	82
LS25-24	24V	22 - 27.2	1.1	120	120	120	84
LS25-36	36V	32 - 40	0.75	150	150	150	85
LS25-48	48V	42 - 54	0.57	180	180	200	85
LS35-3.3	3.3V	3.0 - 3.3	7	66	16.5	80	73
LS35-5	5V	4.75 - 5.5	7	50	25	80	77
LS35-12	12V	10.8 - 13.2	3	60	60	120	81
LS35-15	15V	13.5 - 16.5	2.4	75	75	120	83
LS35-24	24V	22 - 27.2	1.5	120	120	120	84
LS35-36	36V	32 - 40	1	150	150	150	84
LS35-48	48V	42 - 54	0.8	180	180	200	84
LS50-3.3	3.3V	3.0 - 3.6	10	40	20	80	75
LS50-5	5V	4.75 - 5.5	10	40	20	80	80
LS50-12	12V	10.8 - 13.2	4.2	96	48	120	84
LS50-15	15V	13.5 - 16.5	3.4	120	60	120	85
LS50-24	24V	22 - 27.2	2.2	192	96	120	86
LS50-36	36V	32 - 40	1.4	288	144	150	86
LS50-48	48V	42 - 54	1.1	384	192	200	86
LS75-3.3	3.3V	3.0 - 3.6	15	40	20	80	75
LS75-5	5V	4.75 - 5.5	12	40	20	80	79
LS75-12	12V	10.8 - 13.2	6	96	48	120	84
LS75-15	15V	13.5 - 16.5	5	120	60	120	85
LS75-24	24V	22 - 27.2	3.2	192	96	120	86
LS75-36	36V	32 - 40	2.1	288	144	150	86
LS75-48	48V	42 - 54	1.6	384	192	200	87
LS100-3.3	3.3V	3.0 - 3.3	20	66	16.5	80	74
LS100-5	5V	4.75 - 5.5	16	50	25	80	77
LS100-12	12V	10.8 - 13.2	8.5	60	60	120	81
LS100-15	15V	13.5 - 16.5	7	75	75	120	82
LS100-24	24V	22 - 27.2	4.5	120	120	120	84
LS100-36	36V	32 - 40	3	150	150	150	84
LS100-48	48V	42 - 54	2.3	180	180	200	84
LS150-3.3	3.3V	3.0 - 3.3	30	66	16.5	80	74
LS150-5	5V	4.75 - 5.5	26	50	25	80	78
LS150-12	12V	10.8 - 13.2	12.5	60	60	120	83
LS150-15	15V	13.5 - 16.5	10	75	75	120	84
LS150-24	24V	22 - 27.2	6.5	120	120	120	86
LS150-36	36V	32 - 40	4.3	150	150	150	86
LS150-48	48V	42 - 54	3.3	180	180	200	87

Notes: See page 1

- (1) Switch selectable for 115 or 230VAC
- (2) LS50, LS75-3.3 & -5: Derate linearly to 70% load from +50 to +70°C.  
 LS75-12,-15,-24,-36,-48 Derate linearly to 60% load from +50 to +70°C.  
 LS100-3.3 & 5 Derate linearly to 60% load from +45 to +70°C. Derate linearly to 80% load from 115V to 88VAC input.  
 LS100-12,-15,-24,-36,-48 Derate linearly to 60% load from +50 to +70°C. Derate linearly to 80% load from 115V to 88VAC input.  
 LS150-3.3 & 5 Derate linearly to 50% load from +40 to +70°C.  
 LS150-12,-15,-24,-36,-48 Derate linearly to 70% load from +50 to +70°C.

## Outline Drawing LS25

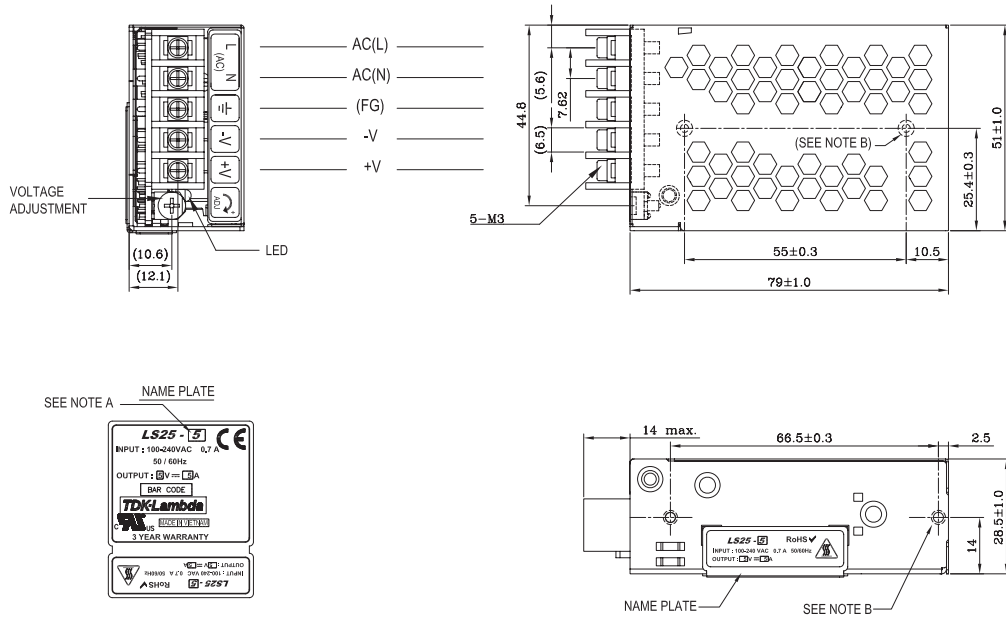

**NOTES**

- A. MODEL NAME, INPUT VOLTAGE RANGE, NOMINAL OUTPUT VOLTAGE, MAXIMUM OUTPUT CURRENT & COUNTRY OF MANUFACTURE ARE SHOWN IN ACCORDANCE WITH THE SPECIFICATION.
- B. M3 TAPPED, EMBOSSED & COUNTERSUNK HOLES (4) FOR CUSTOMER CHASSIS MOUNTING. SCREWS MUST NOT PROTRUDE INTO POWER SUPPLY BY MORE THAN 4mm.
- C. UNLESS OTHERWISE SPECIFIED, DIMENSION TOLERANCE = ±0.3mm.

## Outline Drawing LS35

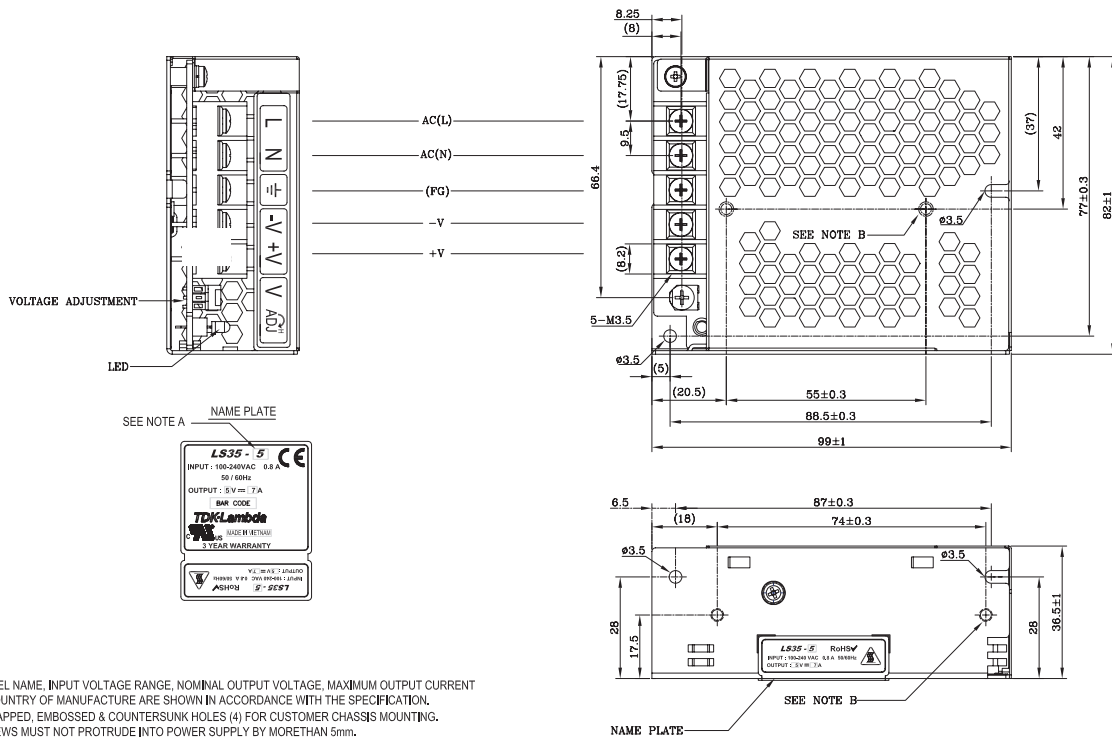

**NOTES**

- A. MODEL NAME, INPUT VOLTAGE RANGE, NOMINAL OUTPUT VOLTAGE, MAXIMUM OUTPUT CURRENT & COUNTRY OF MANUFACTURE ARE SHOWN IN ACCORDANCE WITH THE SPECIFICATION.
- B. M3 TAPPED, EMBOSSED & COUNTERSUNK HOLES (4) FOR CUSTOMER CHASSIS MOUNTING. SCREWS MUST NOT PROTRUDE INTO POWER SUPPLY BY MORE THAN 5mm.
- C. UNLESS OTHERWISE SPECIFIED, DIMENSION TOLERANCE = ±0.3mm.

## Outline Drawing LS50

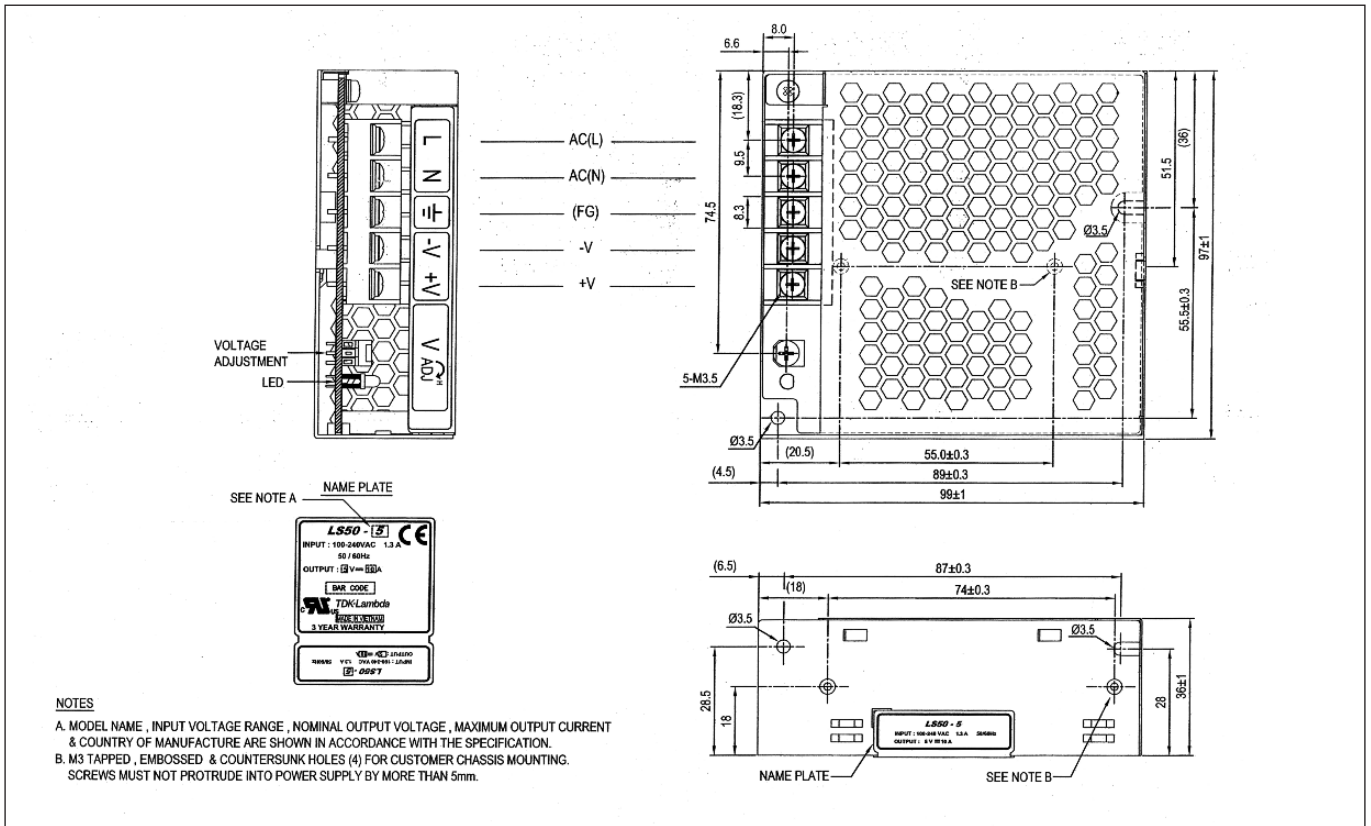

## Outline Drawing LS75

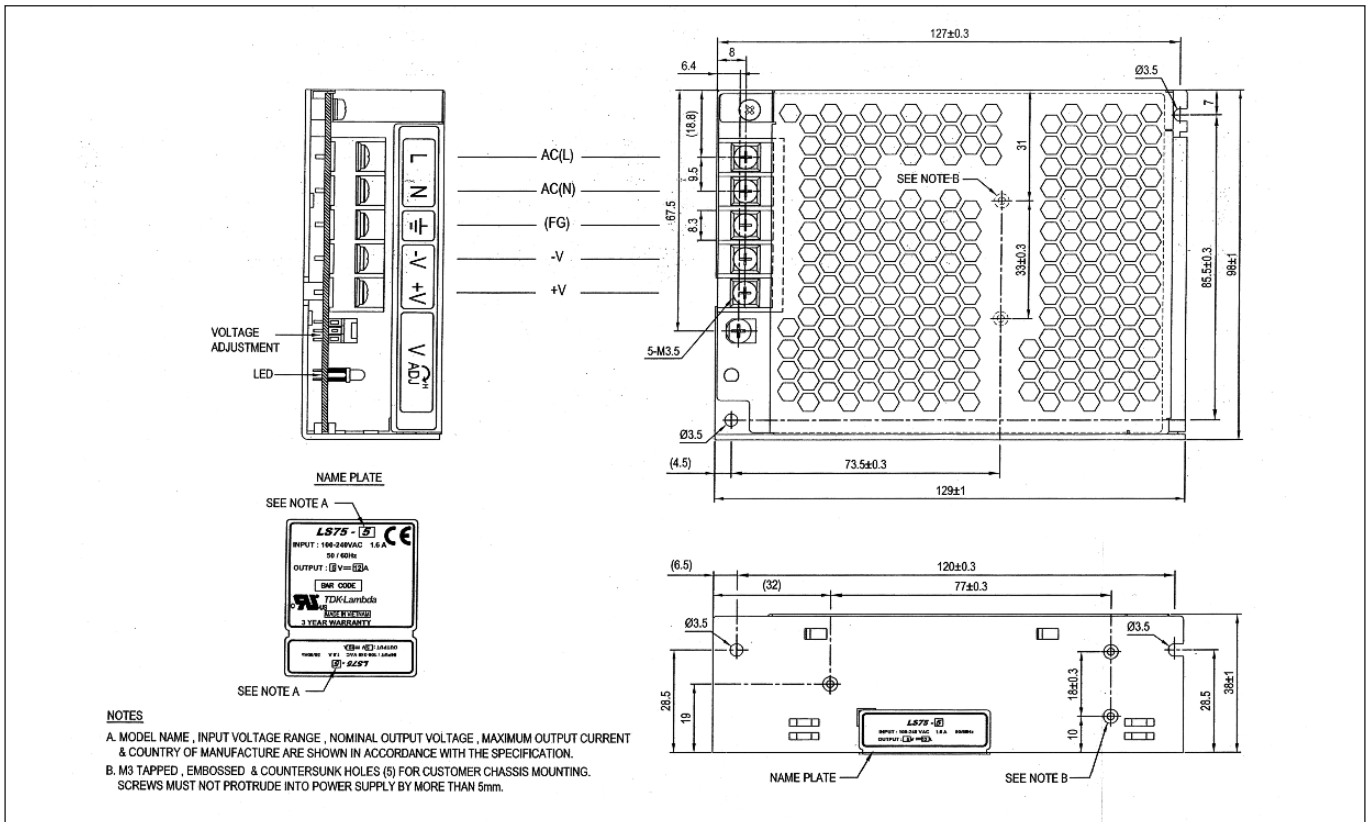

## Outline Drawing LS100

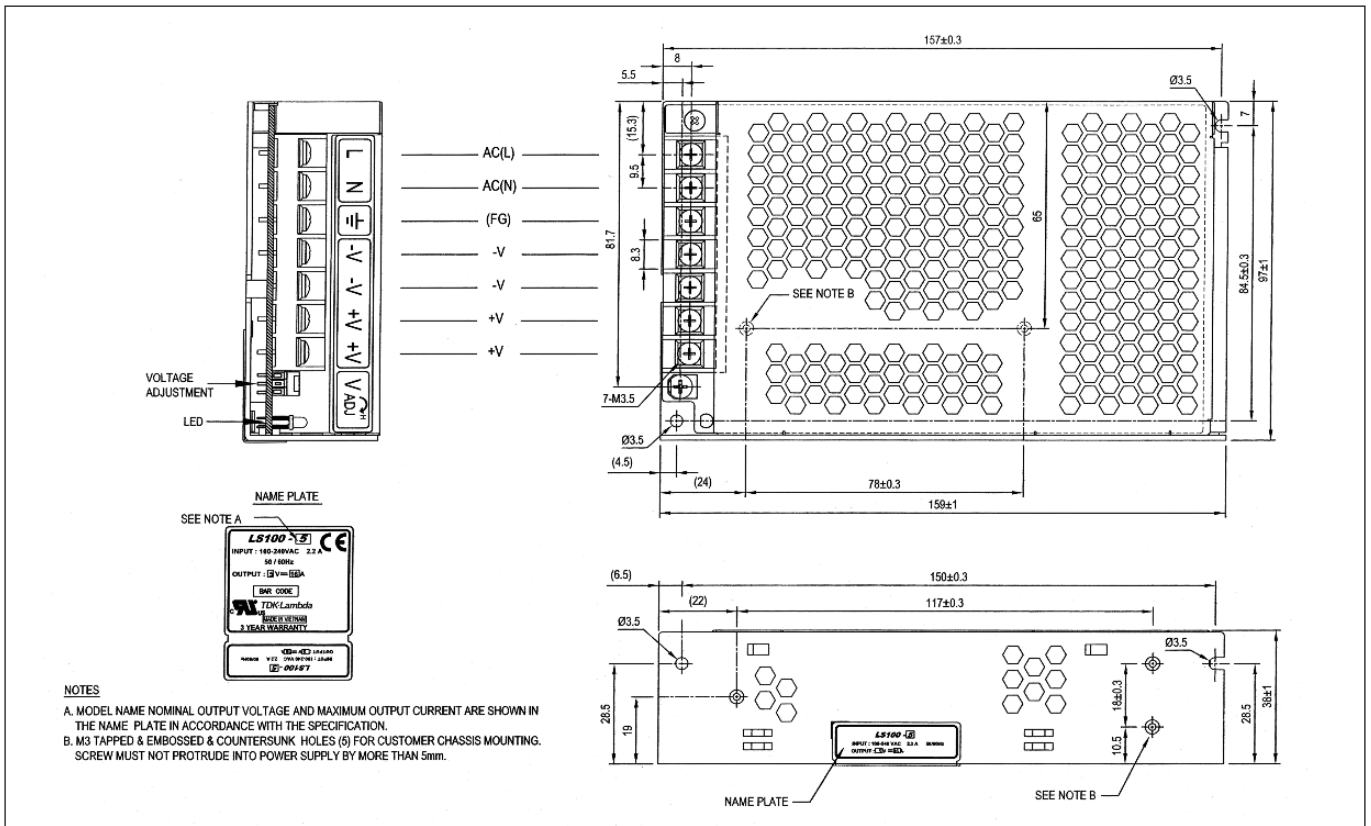

## Outline Drawing LS150

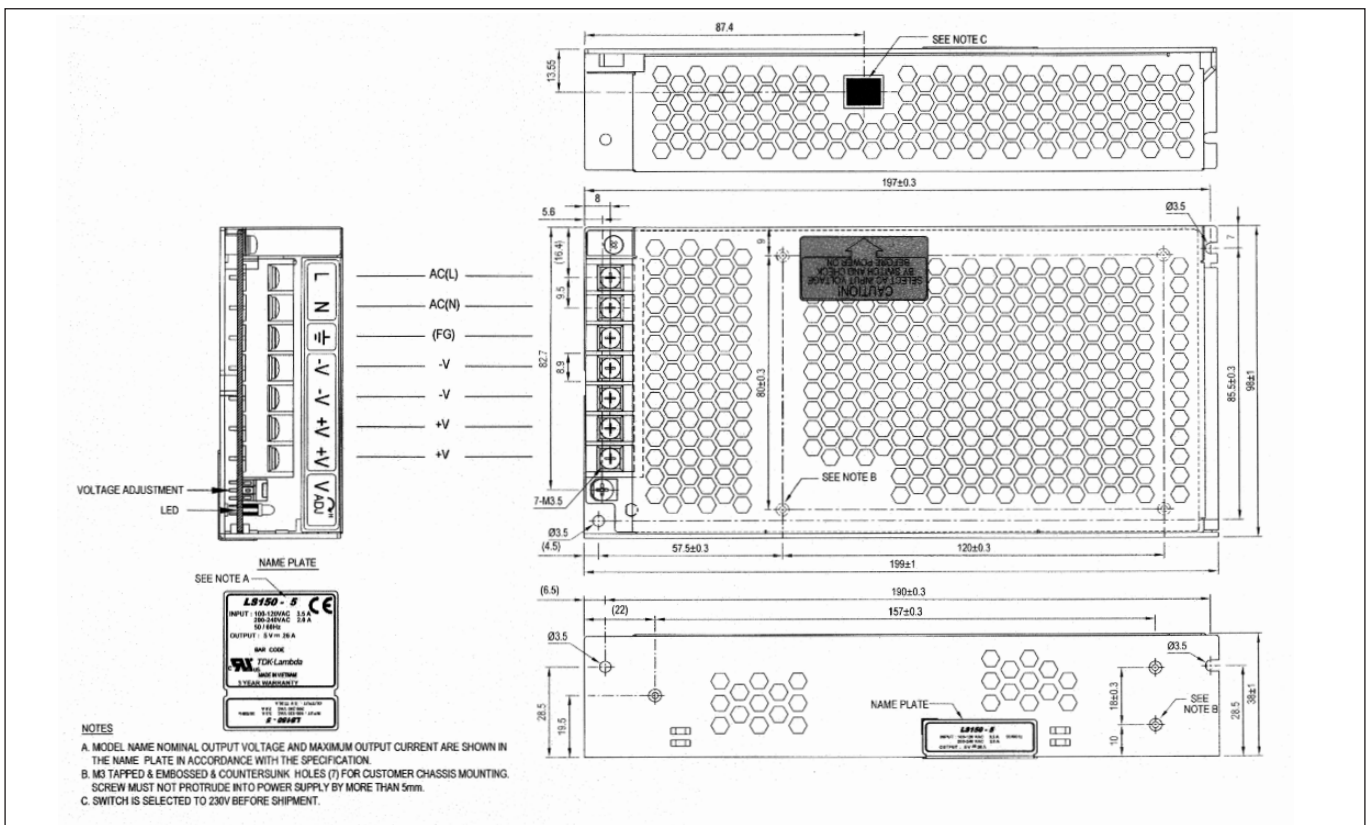



## TDK-LAMBDA EMEA

[www.emea.tdk-lambda.com](http://www.emea.tdk-lambda.com)



### TDK-Lambda France SAS

ZAC des Delaches  
CS 41077  
9 rue Thuillere  
91978 Villebon Courtaboeuf  
France  
Tel: +33 1 60 12 71 65  
Fax: +33 1 60 12 71 66  
[france@fr.tdk-lambda.com](mailto:france@fr.tdk-lambda.com)  
[www.fr.tdk-lambda.com](http://www.fr.tdk-lambda.com)



### Italy Sales Office

Via dei Lavoratori 128/130  
20092 Cinisello Balsamo (MI)  
Italy  
Tel: +39 02 61 29 38 63  
Fax: +39 02 61 29 09 00  
[info.italia@it.tdk-lambda.com](mailto:info.italia@it.tdk-lambda.com)  
[www.it.tdk-lambda.com](http://www.it.tdk-lambda.com)



### Netherlands

[info@tdk-lambda.nl](mailto:info@tdk-lambda.nl)  
[www.tdk-lambda.nl](http://www.tdk-lambda.nl)



### TDK-Lambda Germany GmbH

Karl-Bold-Strasse 40  
77855 Achern  
Germany  
Tel: +49 7841 666 0  
Fax: +49 7841 5000  
[info.germany@de.tdk-lambda.com](mailto:info.germany@de.tdk-lambda.com)  
[www.de.tdk-lambda.com](http://www.de.tdk-lambda.com)



### Austria Sales Office

Aredstrasse 22  
2544 Leobersdorf  
Austria  
Tel: +43 2256 655 84  
Fax: +43 2256 645 12  
[info.germany@de.tdk-lambda.com](mailto:info.germany@de.tdk-lambda.com)  
[www.de.tdk-lambda.com](http://www.de.tdk-lambda.com)



### Scandinavia Sales Office

Valdemarsgade 7  
4100 Ringsted  
Denmark  
Tel: +45 58 10 35 56  
Fax: +45 69 80 44 99  
[info@de.tdk-lambda.com](mailto:info@de.tdk-lambda.com)  
[www.emea.tdk-lambda.com](http://www.emea.tdk-lambda.com)

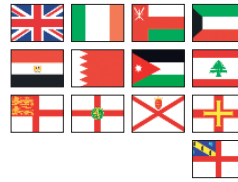

### TDK-Lambda UK Ltd.

Kingsley Avenue  
Ilfracombe  
Devon EX34 8ES  
United Kingdom  
Tel: +44 (0) 12 71 85 66 66  
Fax: +44 (0) 12 71 86 48 94  
[powersolutions@uk.tdk-lambda.com](mailto:powersolutions@uk.tdk-lambda.com)  
[www.uk.tdk-lambda.com](http://www.uk.tdk-lambda.com)



### TDK-Lambda Ltd.

Kibbutz  
Givat Hashlosha 48800  
Israel  
Tel: +9 723 902 4333  
Fax: +9 723 902 4777  
[info@tdk-lambda.co.il](mailto:info@tdk-lambda.co.il)  
[www.tdk-lambda.co.il](http://www.tdk-lambda.co.il)



### Russia

#### Technical Support:

St Petersburg  
Tel: +7 (812) 6580463

#### Sales:

Moscow  
[info@tdk-lambda.ru](mailto:info@tdk-lambda.ru)  
[www.tdk-lambda.ru](http://www.tdk-lambda.ru)

## Local Distribution

