

FX2NC-4DA Analog output block

Thank you very much for purchasing this product.

In order to handle the product properly please read this manual thoroughly before starting to use the product.

User's Manual

MODEL	FX2NC-4DA
MANUAL Number	JY997D07601A
Date	June 2003

Guidelines for the Safety of the User and Protection of the FX2NC-4DA special function block.

This manual should be used by trained and competent personnel. The definition of such a person or persons is as follows:

- Any engineer using the product associated with this manual, should be of a competent nature, trained and qualified to the local and national standards. These engineers should be fully aware of all aspects of safety with regards to automated equipment.
- Any commissioning or service engineer must be of a competent nature, trained and qualified to the local and national standards.
- All operators of the completed equipment should be trained to use this product in a safe and coordinated manner in compliance to established safety practices.

Note: The term "completed equipment" refers to a third party constructed device which contains or uses the product associated with this manual.

●Note concerning the CE marking●

CE Marking does not guarantee that an entire mechanical module produced in accordance with the contents of the notification comply with the following standards. Compliance to EMC standards of the entire mechanical module should be checked by the user / manufacturer.

Standards with which this product complies

Type : Programmable Controller (Open Type Equipment)

Models : Products manufactured starting April 1st, 2003.

Electromagnetic Compatibility Standards (EMC)	Remark
EN61000-6-4:2001 Electromagnetic compatibility -Generic standards - Emission standard for Industrial environment	Compliance with all relevant aspects of the standard. (Radiated Emissions and Mains Terminal Voltage Emissions)
EN61000-6-2:2001 Electromagnetic compatibility -Generic standards Immunity for industrial environments.	Compliance with all relevant aspects of the standard. (RF immunity, Fast transients, ESD, Conducted, Surges, Power magnetic fields, Voltage dips and Voltage interruptions)

For more details please contact the local Mitsubishi Electric sales site.

- Notes for compliance to EMC regulation.

It is necessary to install the FX2NC-4DA in a shielded metal control panel. For further information manual concerning the FX Series, refer to the following table.

List of Further Information Manuals

Manual Name	Manual No.	Description
FX2NC Hardware Manual	JY992D76401	This manual contains hardware explanations of wiring, installation and specifications for the FX2NC Series programmable controllers.
FX Programming Manual II	JY992D88101	This manual contains instruction explanations for the FX1S, FX1N, FX2N and FX2NC Series programmable controllers.

1. Introduction

The FX2NC-4DA analog output block (hereafter referred to as "FX2NC-4DA") converts 4 digital values (from the PLC main unit) into analog output values (voltage or current). The FX2NC-4DA can be connected to the FX2NC Series PLC.

- Each analog output channel can be configured for voltage output, or current output. The output mode must be set using the TO instruction and the appropriate connection method. A different analog output can be selected for each channel.
- The voltage output ranges from -10 to 10 V. The current output ranges from 4 to 20 mA and from 0 to 20 mA. The output characteristics can be adjusted for each channel.
- The resolution is 5 mV (10 V × 1/2000) when the voltage output is used, 20 μA (20 mA × 1/1000) when the current output is used.
- Data transfer with the PLC is performed via the buffer memories of the FX2NC-4DA by FROM/TO instructions.

2. External Dimensions and Part Name

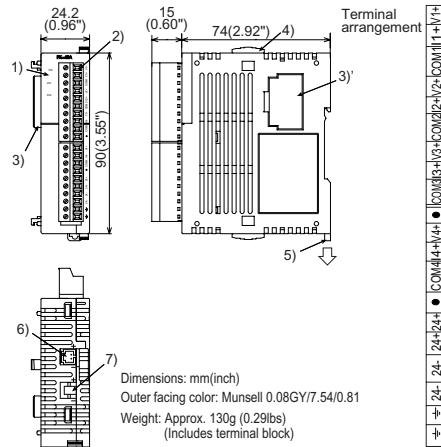

Accessory: Special function block number label, Power crossover cable
FX2NC-10BPCB1

- Status indicator LED
 - Terminal connector (European type)
 - 3) Extension port
 - Slide lock for extension block
 - DIN rail clip
 - Power supply connector (24V DC)
 - Power supply connector (Supply for extension block)
- The connector 3) is equipped with a cover.

- Never wire the terminals.

- Status indicator LED

Indication	Description
PW	Lit while 5 V power is normally supplied from PLC.
24 V	Lit while 24 V power is normally supplied to "24+" and "24-" terminals of the FX2NC-4DA.
D/A	Flashes during D/A conversion.

- Install the FX2NC-4DA on the right side of the main unit, extension block or special function block of the FX2NC Series PLC.

- DIN rail installation

The FX2NC-4DA can be installed on DIN rail DIN46277 (width: 35mm (1.38")). When removing the FX2NC-4DA, push downward on the DIN rail attachment hook.

For further details, refer to the Handy Manual packed together with the PLC main unit.

3. PLC Connection

When connecting the FX2NC-4DA to the FX2NC Series main unit or extension block, remove the extension port cover from the right side of the main unit or extension block, keep the slide lock in the main unit or extension block pulled upward, then align the hook in the FX2NC-4DA with the mounting hole in the former step of the main unit or extension block. Then, push the slide lock downward to fix the FX2NC-4DA. When connecting two or more FX2NC-4DA units, connect an FX2NC-4DA unit to another FX2NC-4DA unit in the same way.

Up to four special function blocks or special function units in total can be connected to the FX2NC Series PLC including those connected to the FX2NC-CNV-IF. For each connected special function block or special function unit, the unit number is assigned starting with 0 for the special function block and special function unit nearest to the main unit. From the main unit, use the FROM/TO instructions to read or write data stored in the FX2NC-4DA.

4. Wiring

4.1 Power supply wiring

Supply power (24V DC) to the FX2NC-4DA to either the power supply connector or the power supply terminal.

When using the power supply connector, the following power cables are available.

Power cables

FX2NC-10BPCB1: Power crossover cable (offered as an accessory for the FX2NC-4DA)

FX2NC-100BPCB: Power cable (offered as an accessory for the FX2NC Series main unit)

- Connection example with the power supply through the crossover connector of the FX2NC input extension block

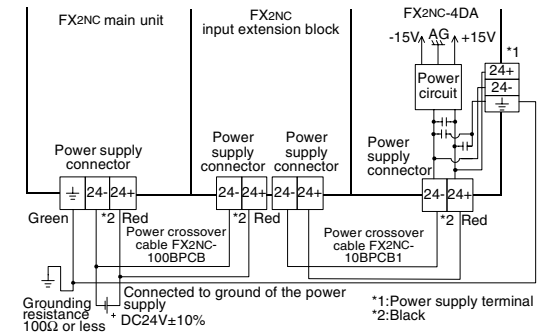

- Connection example to the external power supply through the power supply connector

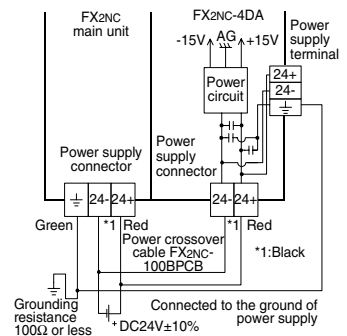

- Connection example to the external power supply through the power supply terminal

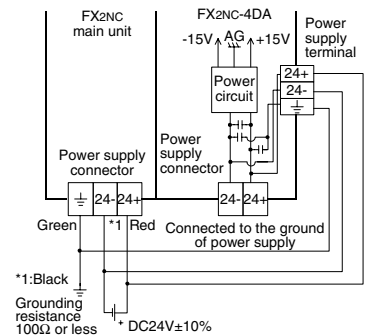

- Do not use both the power supply connector and the power supply terminal at the same time.
- Connect the "⊖" terminal, and the ground terminal of the PLC main unit to the ground of the power supply equipped with grounding resistance of 100Ω or less.
- "24+" and "24-" of the power supply connector and the power supply terminal are connected inside the FX2NC-4DA respectively.
- For crossover wiring to the next block of the FX2NC-4DA, remove the resin cover from the power supply connector.

4.2 Output wiring

For terminal arrangement, refer to Chapter 2 of this manual.

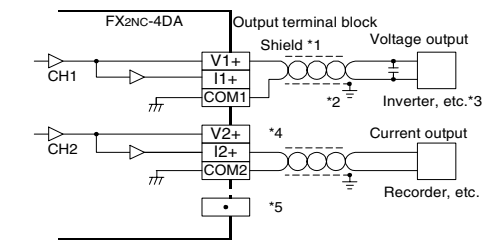

- When wiring the analog output cable, use a shielded two-core twisted cable, and separate it from other power cables and cables easily affected by induction.
- Ground the shielded cable at one point on the signal receiving side. (Grounding resistance 100Ω or less)
- If the output contains noise and ripple, connect a capacitor of approximately 0.1 to 0.47μF, 25 V.
- Do not short-circuit the voltage output terminal. Do not connect a load for the current output to the voltage output terminal.
- Do not wire the "•" terminal.

- Mixed outputs (voltage output and current output) in the same channel are not allowed.

Terminal connector handling

The FX2NC-4DA is equipped with a terminal connector whose form is equivalent to that of the terminal connector type FX2NC PLC.

For the specifications of the suggested screwdriver, the dimensions of the cable terminal, the external dimensions of the bar terminal equipped with insulating sleeve, and applicable wiring, refer to the FX2NC Handy Manual.

5. Specifications

5.1 General specifications

The general specifications are equivalent to those of the PLC main unit. (Refer to the FX2nc Handy Manual.)

5.2 Power supply specifications

Item	Specifications
Analog circuits	24 V DC±10%, 130 mA, externally supplied
Digital circuits	5 V DC, 30 mA, supplied from the PLC main unit using an extension port

5.3 Performance specifications

Item	Voltage output	Current output
Analog output range	-10V DC to 10V DC (External load resistance: 2kΩ to 1MΩ).	DC 0mA to 20mA (External load resistance: 500Ω or less).
Digital input	Effective numeric value (11 bits) + Sign (1 bit)	Effective numeric value (10 bits) + Sign (1 bit)
Resolution	5mV (10V × 1/2000)	20μA (20mA × 1/1000)
Total accuracy	25°C ± 5°C; ±0.5% (at full scale of 20V) 0°C to 55°C; ±1.0% (at full scale of 20V) (Excluding load fluctuation)	25°C ± 5°C; ±0.5% (at full scale of 16mA) 0°C to 55°C; ±1.0% (at full scale of 16mA)
Conversion speed	2.1ms for 4 channels (A change in the number of channels used will not change the conversion speed.)	
Isolated method	Analog output and PLC are isolated by photocoupler. Power supply and analog output are isolated by transformer. (Channels are not isolated from each other.)	
Number of occupied I/O points	8 points. (Including input and output points)	
Applicable PLC	FX2NC Series PLC (Up to four units can be connected including special function blocks and special function units connected to FX2nc-CNV-IF)	
Built-in memory	EEPROM	
I/O characteristics (Default: mode 0)	<p>Mode 0 (Voltage output: -10V to 10V) At the load resistance of 10kΩ</p>	
I/O characteristics can be adjusted using the procedure described in Section 9 in this manual.)	<p>Mode 1 (Current output: 4mA to 20mA) At the load resistance of 250Ω</p>	
	<p>Mode 2 (Current output: 0mA to 20mA) At the load resistance of 250Ω</p>	
	<p>A command sent from the programmable controller can change the mode. The voltage/current output mode selected will determine the output terminals used.</p>	

6. Buffer Memory (BFM)

The FX2nc-4DA exchanges data with the PLC via the buffer memory addresses (16-bit data) in the FX2nc-4DA.

BFM #0 to #5, #8 to #17, #20 and #21 can be written by the PLC using the TO instruction. BFM #29 and #30 can be read using the FROM instruction.

6.1 Buffer Memories (BFM) lists

BFM No.	Description
#0 *1	Output mode select. Factory setting H0000
#1	Output data CH1
#2	Output data CH2
#3	Output data CH3
#4	Output data CH4
#5 *1	Data holding mode. Factory setting H0000
#6, #7	Reserved
#8	Offset/gain setting command CH1, CH2 Initial value H0000
#9	Offset/gain setting command CH3, CH4 Initial value H0000
#10	Offset data CH1 *2
#11	Gain data CH1 *3
#12	Offset data CH2 *2
#13	Gain data CH2 *3
#14	Offset data CH3 *2
#15	Gain data CH3 *3
#16	Offset data CH4 *2
#17	Gain data CH4 *3
#18, #19	Reserved
#20	Initialize. initial value = 0
#21 *1	I/O characteristics adjustment inhibit (Initial value b1=0, b0=1)
#22 to #28	Reserved
#29	Error status
#30	K3020 identification code
#31	Reserved

*1 The status of BFM #0, #5, and #21, will be written to EEPROM, therefore the set values will be retained even after turning OFF the power.

*2 Offset data: Actual analog output value when corresponding output data (BFM #1 to #4) is 0

*3 Gain data: Actual analog output value when corresponding output data (BFM #1 to #4) is 1,000

*4 When current output mode 1 (4 mA to 20 mA) is set, the offset data will be automatically set to 4,000 and the gain data to 20,000. When the current output mode 2 (0 mA to 20 mA) is set, the offset data will be automatically set to 0 and the gain data to 20,000.

[BFM #0] Output mode select

The value of BFM #0 switches the analog output between voltage and current for each channel. It takes the form of a 4 digit hexadecimal number. The first digit will be the command for channel 1 (CH1), and the second digit for channel 2 (CH2) etc. The numeric values of these four digits respectively represent the following items:

H ○ ○ ○ ○ O = 0: Sets the voltage output mode (-10 V to 10 V).
 O = 1: Sets the current output mode (4 mA to 20 mA).
 O = 2: Sets the current output mode (0 mA to 20 mA).

Switching the output mode resets the I/O characteristics to the factory-default characteristics. Refer to the performance specifications described in section 5. Example: H2110CH1: Voltage output (-10 V to 10 V)

CH2 and CH3: Current output (4 mA to 20 mA)
 CH4: Current output (0 mA to 20 mA)

[BFM #1, #2, #3 and #4] Output data channels CH1, CH2, CH3, and CH4

BFM #1: Output data of CH1 (Initial value: 0)

BFM #2: Output data of CH2 (Initial value: 0)

BFM #3: Output data of CH3 (Initial value: 0)

BFM #4: Output data of CH4 (Initial value: 0)

[BFM #5] Data holding mode

While the programmable controller is in the STOP mode, the last output value in the RUN mode will be held. To reset the value to the offset value, write the hexadecimal value in BFM #5 as follows:

H ○ ○ ○ ○ O = 0: Holds the output.
 O = 1: Resets to the offset value.

Example: H0011 CH1 and CH2 = Offset value CH3 and CH4 = Output holding

[BFM #8 and #9] Offset/gain setting command

Changes offset and gain values of channels CH1 to CH4 by writing 1 to the corresponding Hex digits of BFM #8 or #9. The current values will be valid until this command is output. (Refer to Chapter 9)



1 to 4: Channel number O = 0: No changes done. O = 1: Change data value.

[BFM #10 to #17] Offset/gain data

The offset and gain values are changed by writing new data to BFM #10 to #17. The units of the data to be written are mV or μA. The data should be written and then BFM #8 and #9 set. Note that the data value will be rounded down to the nearest 5mV or 20μA.

[BFM #20] Initialize

When K1 is written in BFM #20, all values will be returned to the factory-default. (Note that the BFM #20 data will override the BFM #21 data.)

This initialize function is convenient if you have an error in adjustment.

[BFM #21] I/O characteristics adjustment inhibit

Setting BFM #21 to K2 inhibits the user from inadvertent adjustment of I/O characteristics. The adjustment inhibit function, once set, will be valid until the Permit command (BFM #21=K1) is set. The initial value is K1 (Permit). The set value will be retained even after power-OFF.

[BFM #29] Error status

When an error occurs, use the FROM command to read out the details of the error.

Bit	Name	Status when bit is set to "1" (turned ON)	Status when bit is set to "0" (turned OFF)
b0	Error	Error if any of b1 to b4 is turned ON	No error
b1	O/G error	Offset/gain data in EEPROM is abnormal or a data setting error occurs.	Offset/Gain data normal
b2	Power supply error	24V DC power failure	Power supplied normally
b3	Hardware error	Defective D/A converter or other hardware	Functioning hardware
b4	Program error	FROM/TO instruction is used by mistake.	Program is normal.
b10	Range error	The digital input or analog output value is out of the specified range.	The input or output value is in the specified range.
b12	G/O-Adjustment prohibit status	BFM #21 is not set to "K1".	Adjustable status

Bits b4 to b9, b11, b13 to b15 are not defined.

[BFM #30] Identification code

The identification code for a special function block is read using the FROM instruction. The identification code for the FX2nc-4DA unit is K3020. The main unit can use this facility in the program to identify the special function block before commencing any data transfers from and to the special function block. Note:

Values of BFM #0, #5, and #21, are stored in the EEPROM memory of the FX2nc-4DA. BFM #10 to #17 are copied to EEPROM when the gain/offset setting command BFM #8, #9 is used. Also, BFM #20 causes the resetting of the EEPROM memory. The EEPROM has a life of about 10,000 cycles (changes), so do not use programs which frequently change these BFMs.

A mode change of BFM #0 automatically involves a change of the corresponding offset and gain values. Because of the time needed to write the new values to the internal EEPROM memory, a delay of 3 s is required between instructions changing BFM #0 and instructions writing to the corresponding BFM #10 through BFM #17.

Therefore, a delay timer should be used before writing to BFM #10 through #17. (Refer to chapter 9.)

7. Operation and Program Examples

If the factory-default I/O characteristics are not changed and the status information is not used, you can operate the FX2nc-4DA using the following simple program. For the FROM and TO instructions, refer to the FX Programming Manual (II).

CH1 and CH2: Voltage output mode (-10 V to 10 V)

CH3 : Current output mode (4 mA to 20 mA)

CH4 : Current output mode (0 mA to 20 mA)

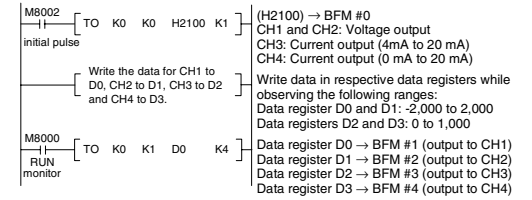

7.1 Operation procedure

- Turn OFF the power of the PLC, and then connect the FX2nc-4DA. After wards, wire the I/O lines of the FX2nc-4DA.
- Set the PLC to STOP, and turn ON the power. Write the above program then switch the PLC to RUN.
- Analog values will be sent from D0 (BFM #1), D1 (BFM #2), D2 (BFM #3), and D3 (BFM #4) to the respective output channels of the FX2nc-4DA. When the PLC is in STOP, the analog values set before stopping the PLC will remain output. (The output will be held.)
- When the PLC is in STOP, the offset values can also be output. For a detailed description, refer to Section 6).

7.2 Program example

In the example shown below, CH1 and CH2 in the FX2nc-4DA, connected to the special function block No. 0, are handled as the voltage output, CH3 is handled as the current output (4 to 20 mA), CH4 is handled as the current output (0 to 20 mA), and these outputs are held when the PLC is stopped. In the example shown below, the status information is utilized.

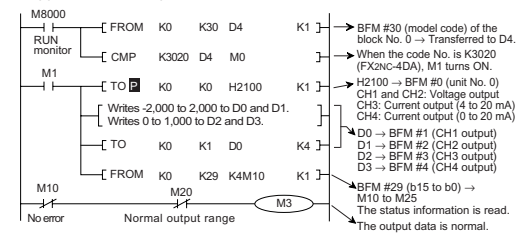

8. Caution Regarding Operation

- Check whether the output wiring and/or the FX2nc-4DA is properly connected to the FX2nc main unit.
- The FX2nc-4DA uses 30mA (5V) supplied from the main unit. Confirm that the total value including the 5V current consumption of other special function blocks is less than the limit.
- The FX2nc-4DA starts operation when the 24V DC power is set to ON. Make such a program that changes over the output of the BFM #0 before writing the output data.
- After the 24V DC power for the FX2nc-4DA is turned ON or OFF, the analog output may fluctuate for approximately 1 second. This is due to time delays in the power supply from the main unit or differences in start time. For this reason, be sure to take preventive measures so that this output fluctuation will not affect the external units.

[Example of preventive measure]

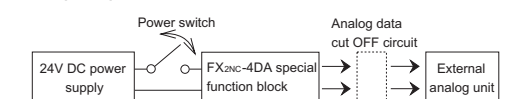

9. Adjustment of the I/O Characteristics

9.1 I/O characteristics

The standard characteristics (factory default) are shown by the solid lines in the figure below. These characteristics can be adjusted to suit the user's application.

Standard characteristics of voltage output

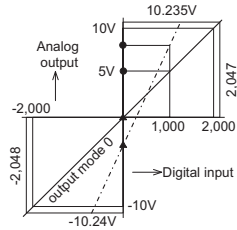

Standard characteristics of current output (4mA to 20mA)

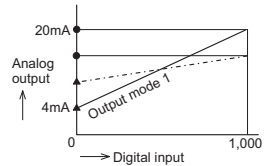

Standard characteristics of current output (0mA to 20mA)

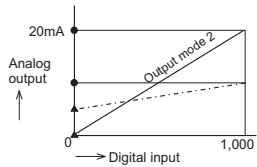

- ...Gain value: Analog output value when the digital input is 1,000
 - ▲ ...Offset value: Analog output value when the digital input is 0
- Offset and gain can be set independently or together. Possible offset ranges are -5V to 5V or -20mA to 20mA, and gainvalue-offset value=1V to 15V or 4mA to 32mA. (Actual output can only be a positive value.) Gain and offset can be adjusted from software in the main unit.

When the slope of the I/O characteristic line is steep:
Slight changes to the digital input will greatly increase or reduce the analog output.

When the slope of the I/O characteristic line is gentle:
Slight changes to the digital input will not always change the analog output.

Note

That the resolution (minimum possible change of analog output) of the FX2NC-4DA is fixed.

9.2 Adjustment of I/O Characteristics

An example program for adjustment is shown below. The example shows that for channel CH2 of FX2NC-4DA block No.1, the offset value is changed to 7 mA, and the gain value to 20 mA. Note that for CH1, CH3, and CH4, the standard voltage output characteristics are set.

9.3 Program Examples

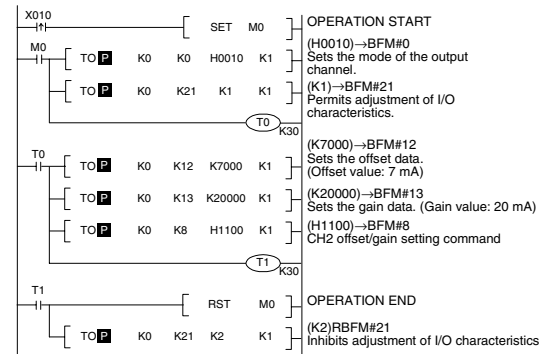

Characteristics after the calibrations above.

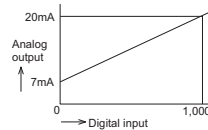

10. Troubleshooting

If the FX2NC-4DA does not operate properly, check the following items

- 1) Check the external wiring. Refer to section 4 of this manual.
- 2) Check status of the POWER indicator lamp (LED) of the FX2NC-4DA.
 - ON : The special function block is properly connected.
 - OFF or flash : Check the connection of the special function block. Also check the 5V power supply capacity.
- 3) Check status of the 24 V power indicator lamp (LED) of the FX2NC-4DA.
 - ON : 24V DC is supplied.
 - OFF : Supply 24V DC ($\pm 10\%$) 130mA to the FX2NC-4DA.
- 4) Check the status of the D/A conversion indicator lamp (LED) of the FX2NC-4DA.
 - Flash : D/A conversion is normal.
 - ON or OFF : The ambient conditions are not suitable for the FX2NC-4DA, or the FX2NC-4DA is defective.
- 5) Check that the external load resistance connected to each analog output terminal does not exceed the capacity of the FX2NC-4DA drive (voltage output: 2k Ω to 1 M Ω / current output: 500 Ω or less).
- 6) Check the output voltage or current value using a voltmeter or ammeter, and confirm that the output meets the I/O characteristics. If the output does not meet the I/O characteristics, adjust the offset and gain again. Refer to section 9.

Note

To test the withstand voltage of the FX2NC-4DA, connect all the terminals to the grounding terminal.